

REVISION		
DATE	L.S. NAME	LIC. #
JAN. 1993	THOMAS CRADER	21782
SEPT. 2000	THOMAS CRADER	21782
JULY 2009	MICHAEL MCGURL	38338
JAN. 2016	CHARLES E. ADAMSON	42627
NOV. 2018	CHARLES E. ADAMSON	42627
MAR. 2021	CHARLES E. ADAMSON	42627

LOT 2
8.78± AC. TOTAL
BOROUGH OF SEASIDE PARK — EXEMPTED

97

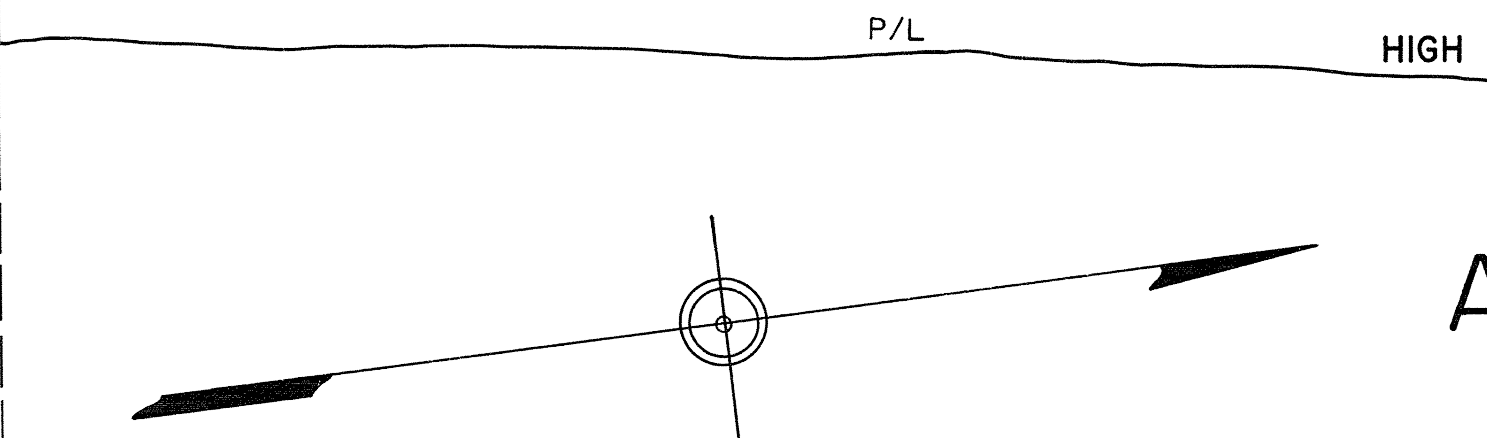
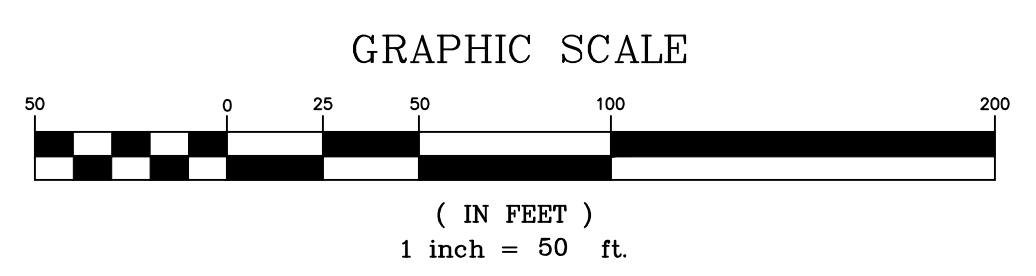

ATLANTIC

OCEAN

THIS SHEET HAS BEEN REVISED USING COMPUTER AIDED DRAFTING/DESIGN. (CADD)

THIS SHEET IS A SCANNED COPY OF THE TAX MAP PREPARED BY REMINGTON & VERNICK ENGINEERS DATED DECEMBER 1986. THE ORIGINAL APPROVED MAP IS ON FILE AT CME ASSOCIATES, HOWELL, NEW JERSEY.

NEW JERSEY DEPARTMENT OF THE TREASURY
DIVISION OF TAXATION
LOCAL PROPERTY BRANCH
APPROVED AS A TAX MAP PURSUANT TO THE PROVISIONS OF CHAPTER 170, LAWS OF 1915, ETC. FOR THE DIRECTOR, DIVISION OF TAXATION

John J. Johnson

BY: *John J. Johnson* P.E. & L.S.
DATE: 12-15-86

TAX MAP
BOROUGH OF SEASIDE PARK
OCEAN COUNTY, NEW JERSEY
SCALE 1" = 50'
DECEMBER 1986
CRAIG F. REMINGTON, L.S.
REMINGTON & VERNICK ENGINEERS
9 ALLEN STREET, TOMS RIVER, NEW JERSEY